

# ST 2SB1424U

## PNP Silicon Epitaxial Planar Transistor

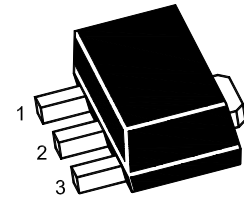

1.Base 2.Collector 3.Emitter  
SOT-89 Plastic Package

### Absolute Maximum Ratings ( $T_a = 25\text{ }^\circ\text{C}$ )

Parameter	Symbol	Value	Unit
Collector Base Voltage	$-V_{CBO}$	20	V
Collector Emitter Voltage	$-V_{CEO}$	20	V
Emitter Base Voltage	$-V_{EBO}$	6	V
Collector Current - DC	$-I_C$	3	A
Collector Current - Pulse <sup>1)</sup>	$-I_{CP}$	5	A
Total Power Dissipation	$P_{tot}$	0.5	W
Junction Temperature	$T_J$	150	$^\circ\text{C}$
Storage Temperature Range	$T_S$	- 55 to + 150	$^\circ\text{C}$

<sup>1)</sup> Single pulse, PW = 10 ms.

### Characteristics at $T_a = 25\text{ }^\circ\text{C}$

Parameter	Symbol	Min.	Typ.	Max.	Unit	
DC Current Gain at $-V_{CE} = 2\text{ V}$ , $-I_C = 100\text{ mA}$	Current Gain Group Q R	$h_{FE}$	120	-	270	-
		$h_{FE}$	180	-	390	-
Collector Base Breakdown Voltage at $-I_C = 50\text{ }\mu\text{A}$	$-V_{(BR)CBO}$	20	-	-	V	
Collector Emitter Breakdown Voltage at $-I_C = 1\text{ mA}$	$-V_{(BR)CEO}$	20	-	-	V	
Emitter Base Breakdown Voltage at $-I_E = 50\text{ }\mu\text{A}$	$-V_{(BR)EBO}$	6	-	-	V	
Collector Cutoff Current at $-V_{CB} = 20\text{ V}$	$-I_{CBO}$	-	-	0.1	$\mu\text{A}$	
Emitter Cutoff Current at $-V_{EB} = 5\text{ V}$	$-I_{EBO}$	-	-	0.1	$\mu\text{A}$	
Collector Emitter Saturation Voltage at $-I_C = 2\text{ A}$ , $-I_B = 100\text{ mA}$	$-V_{CE(sat)}$	-	-	0.5	V	
Transition Frequency at $-V_{CE} = 2\text{ V}$ , $-I_E = 0.5\text{ A}$ , $f = 100\text{ MHz}$	$f_T$	-	240	-	MHz	
Output Capacitance at $-V_{CB} = 10\text{ V}$ , $f = 1\text{ MHz}$	$C_{ob}$	-	35	-	pF	

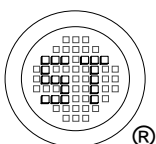

**SEMTECH ELECTRONICS LTD.**

(Subsidiary of Sino-Tech International Holdings Limited, a company  
listed on the Hong Kong Stock Exchange, Stock Code: 724)

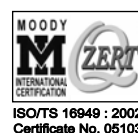

ISO/TS 16949 : 2002  
Certificate No. 05103



ISO 14001:2004  
Certificate No. 71116



ISO 9001:2000  
Certificate No. 0506098

Dated : 15/12/2006

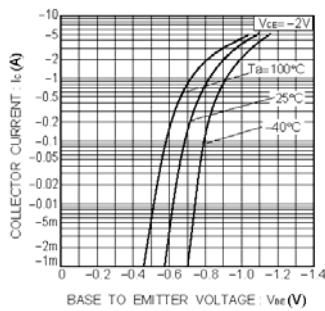

Fig.1 Grounded emitter propagation characteristics

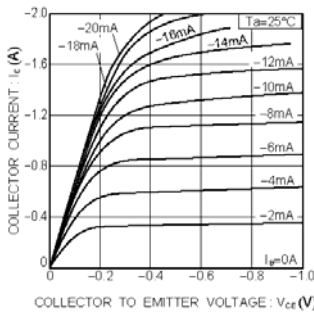

Fig.2 Grounded emitter output characteristics (I)

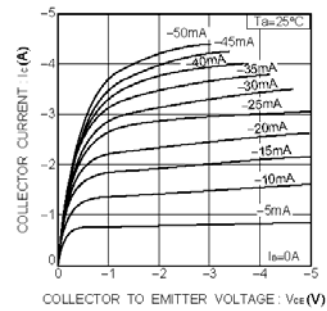

Fig.3 Grounded emitter output characteristics (II)

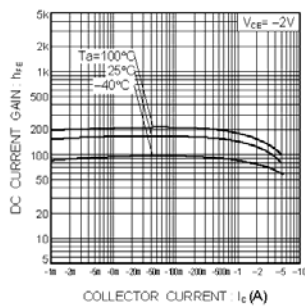

Fig.4 DC current gain vs. collector current

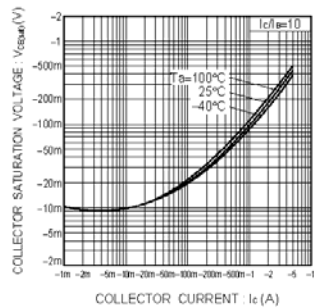

Fig.5 Collector-emitter saturation voltage vs. collector current (I)

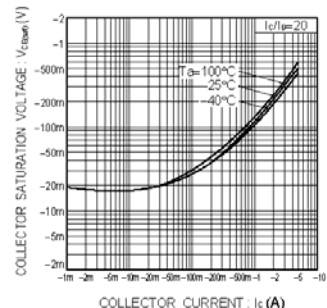

Fig.6 Collector-emitter saturation voltage vs. collector current (II)

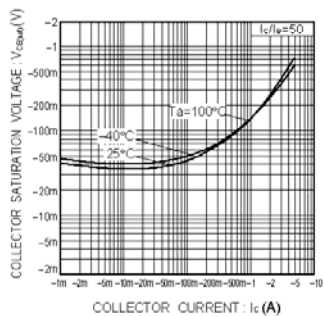

Fig.7 Collector-emitter saturation voltage vs. collector current (III)

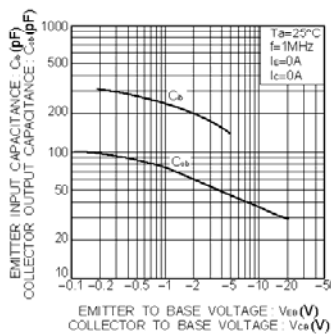

Fig.8 Gain bandwidth product vs. emitter current  
Collector output capacitance vs. collector-base voltage

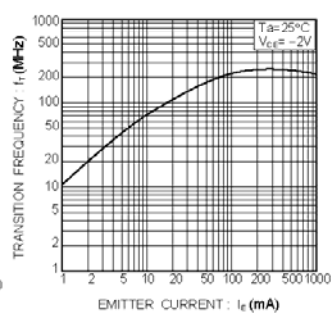
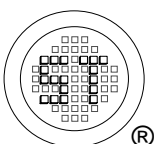
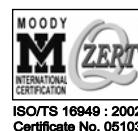

Fig.9 Emitter input capacitance vs. emitter base voltage



**SEMTECH ELECTRONICS LTD.**  
(Subsidiary of Sino-Tech International Holdings Limited, a company listed on the Hong Kong Stock Exchange, Stock Code: 724)



ISO/TS 16949 : 2002 Certificate No. 05103  
ISO 14001:2004 Certificate No. 7116  
ISO 9001:2000 Certificate No. 0506098

# ST 2SB1424U

## SOT-89 PACKAGE OUTLINE

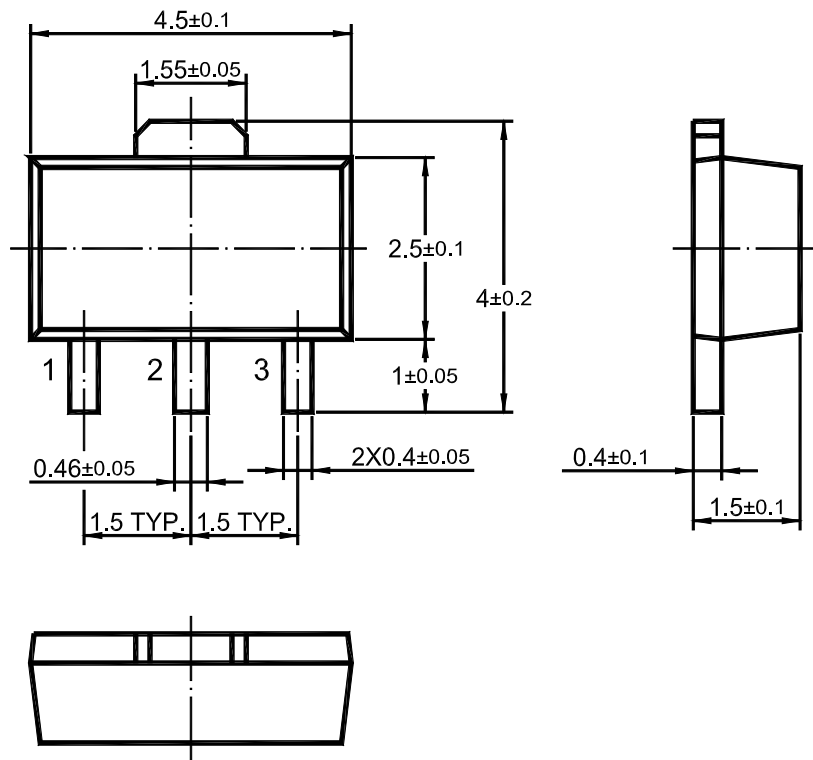

Dimensions in mm

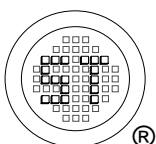

**SEMTECH ELECTRONICS LTD.**  
(Subsidiary of Sino-Tech International Holdings Limited, a company  
listed on the Hong Kong Stock Exchange, Stock Code: 724)



Dated : 15/12/2006