

BAS316WS

Silicon Epitaxial Planar Switching Diode

Applications

- High-speed switching

PINNING

PIN	DESCRIPTION
1	Cathode
2	Anode

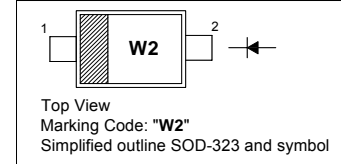

Absolute Maximum Ratings ($T_a = 25\text{ }^\circ\text{C}$)

Parameter	Symbol	Value	Unit
Repetitive Peak Reverse Voltage	V_{RRM}	100	V
Reverse Voltage	V_R	100	V
Continuous Forward Current	I_F	250	mA
Repetitive Peak Forward Current	I_{FRM}	500	mA
Non-Repetitive Peak Forward Current	I_{FSM}	4	A
		1	
		0.5	
Total Power Dissipation	P_{tot}	200	mW
Junction Temperature	T_j	150	$^\circ\text{C}$
Storage Temperature Range	T_{stg}	- 65 to + 150	$^\circ\text{C}$

Characteristics at $T_a = 25\text{ }^\circ\text{C}$

Parameter	Symbol	Max.	Unit
Forward Voltage at $I_F = 1\text{ mA}$ at $I_F = 10\text{ mA}$ at $I_F = 50\text{ mA}$ at $I_F = 150\text{ mA}$	V_F	0.715	V
		0.855	
		1	
		1.25	
Reverse Current at $V_R = 25\text{ V}$ at $V_R = 75\text{ V}$ at $V_R = 25\text{ V}, T_J = 150\text{ }^\circ\text{C}$ at $V_R = 75\text{ V}, T_J = 150\text{ }^\circ\text{C}$	I_R	30	nA
		1	μA
		30	μA
		50	μA
Diode Capacitance at $V_R = 0\text{ V}, f = 1\text{ MHz}$	C_{tot}	1.5	pF
Reverse Recovery Time at $I_F = I_R = 10\text{ mA}, I_{rr} = 0.1 \times I_R, R_L = 100\ \Omega$	t_{rr}	4	ns

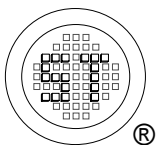

SEMTECH ELECTRONICS LTD.

(Subsidiary of Sino-Tech International Holdings Limited, a company listed on the Hong Kong Stock Exchange, Stock Code: 724)

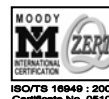

Dated : 15/06/2009

BAS316WS

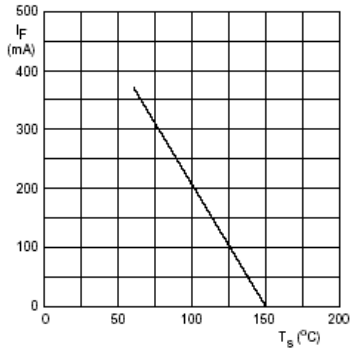
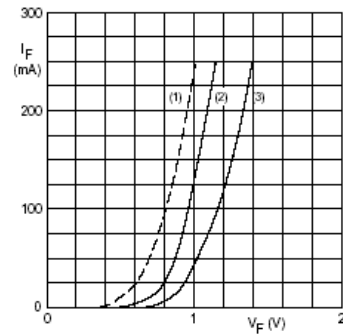
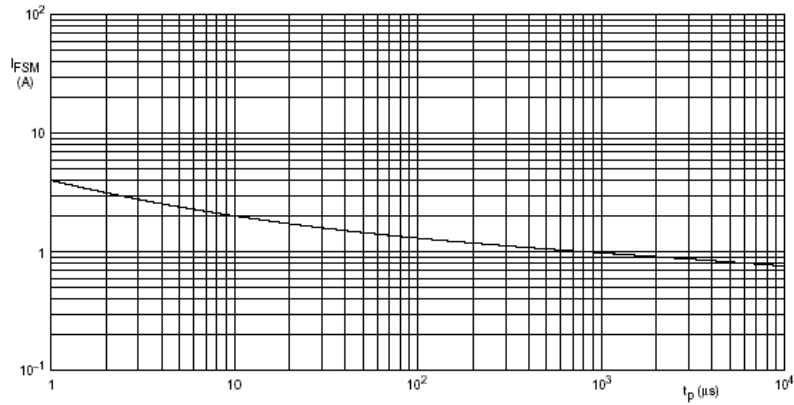

Fig.1 Maximum permissible continuous forward current as a function of soldering point temperature.



(1) $T_j = 150^{\circ}$ C; typical values.
 (2) $T_j = 25^{\circ}$ C; typical values.
 (3) $T_j = 25^{\circ}$ C; maximum values.

Fig.2 Forward current as a function of forward voltage.



Based on square wave currents.
 $T_j = 25^{\circ}$ C prior to surge.

Fig.3 Maximum permissible non-repetitive peak forward current as a function of pulse duration.

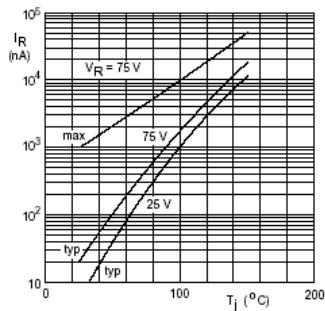
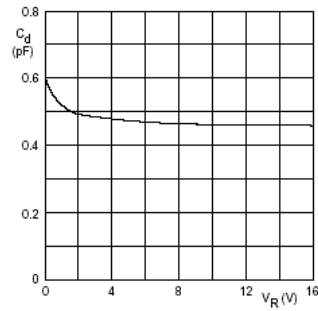
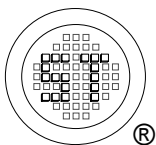

Fig.4 Reverse current as a function of junction temperature.



$f = 1$ MHz; $T_j = 25^{\circ}$ C.

Fig.5 Diode capacitance as a function of reverse voltage; typical values.



SEMTECH ELECTRONICS LTD.

(Subsidiary of Sino-Tech International Holdings Limited, a company listed on the Hong Kong Stock Exchange, Stock Code: 724)

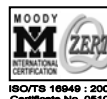

ISO/TS 16949 : 2002
 Certificate No. 05103

ISO 14001:2004
 Certificate No. 7116

ISO 9001:2000
 Certificate No. 0506098

BS-OHSAS 18001: 2007
 Certificate No. 7116

IECQ QC 080000
 Certificate No. 7116

BAS316WS

PACKAGE OUTLINE

Plastic surface mounted package; 2 leads

SOD-323

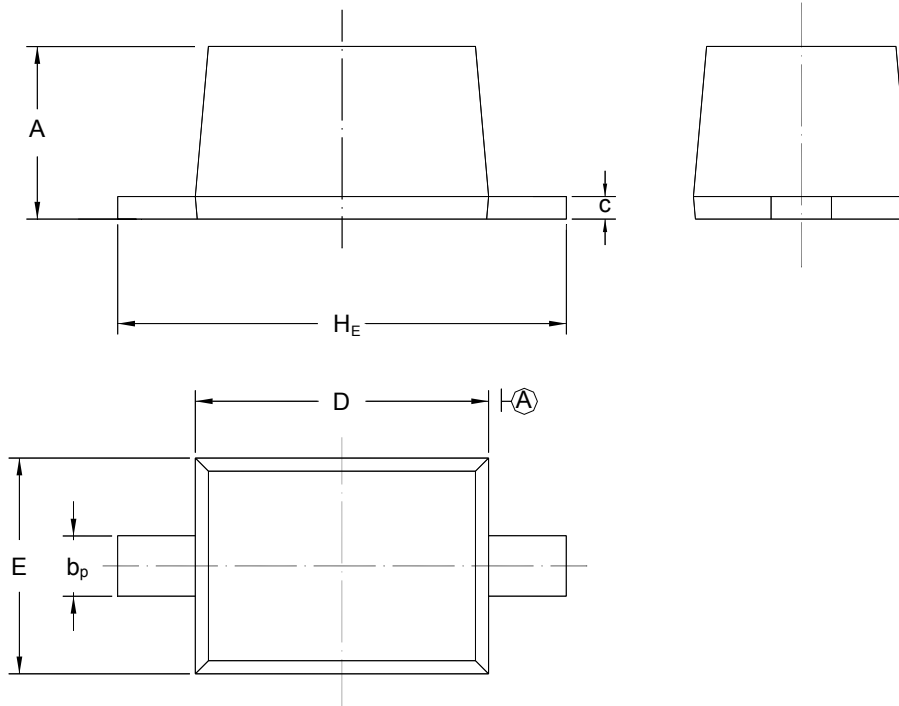

UNIT	A	b _p	C	D	E	H _E
mm	1.10 0.80	0.40 0.25	0.15 0.00	1.80 1.60	1.35 1.15	2.80 2.30

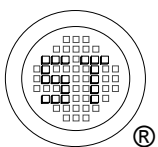

SEMTECH ELECTRONICS LTD.
 (Subsidiary of Sino-Tech International Holdings Limited, a company listed on the Hong Kong Stock Exchange, Stock Code: 724)

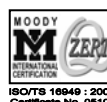

ISO/TS 16949:2002
Certificate No. 05103

ISO 14001:2004
Certificate No. 7116

ISO 9001:2000
Certificate No. 0506098

BS-OHSAS 18001:2007
Certificate No. 7116

IECQ QC 080000
Certificate No. 05103

Dated : 15/06/2009